



**AEP Generation Interconnection
Facilities Study Report
for
ERAS-2025-001
ERAS-2025-024
Comanche 138 kV
Comanche County, Oklahoma**

May 2026

1 Facilities Study Summary

American Electric Power Southwest Transmission Planning (AEP) performed the following study at the request of the Southwest Power Pool (SPP) for SPP Generation Interconnection request ERAS-2025-001; ERAS-2025-024. Per the SPP Generator Interconnection Procedures (GIP), SPP requested that AEP perform an Interconnection Facilities Studies (IFS) for Network Upgrade(s) in accordance with Section 8.11 for the following Interconnection and/or Network Upgrade(s):

1.1 Project Description

ERAS-2025-024 proposes to connect a 744 MW gas generator to the 138 kV Comanche AEP station (Figure 1) in Comanche County, Oklahoma (Figure 2).

1.2 AEP's Scope of Work to Facilitate Interconnection

- To accommodate the interconnections, AEP's existing 138 kV Comanche station will have to be expanded to a breaker and a half configuration. Bus work and disconnect switches will be designed to accommodate the loading requirements, and circuit breakers will be rated to ensure adequate load and fault interrupting capability. AEP will own, operate, and maintain the 138 kV Comanche station.
- Installation of associated protection and control equipment, SCADA, and revenue metering will be required at the AEP 138 kV Comanche station. AEP reserves the right to specify the final acceptable configuration considering design practices, future expansion, and compliance requirements.
- AEP will extend one span of 138 kV transmission line for the generation lead going to the 138 kV Comanche station. AEP will build and own the first transmission line structure outside of the 138 kV Comanche station, to which AEP's transmission line conductor will attach. ROW will be required for this span.
- It is understood that the Interconnection Customer is responsible for all of the connection costs associated with interconnecting ERAS-2025-024 to the AEP transmission system. The cost of the customer's generating facility and the costs for the line connecting the generating facility to AEP's transmission system (Beyond the first span exiting the POI station) are not included in this report; these are assumed to be the Customer's responsibility.
- The customer will be responsible for the cost of constructing a fiber-optic connection from their telecom equipment to AEP's 138 kV Comanche station control house.

1.3 Short Circuit Evaluation

- It is standard practice for AEP to recommend replacing a circuit breaker when the current through the breaker for a fault exceeds 100% of its interrupting rating with recloser de-rating applied, as determined by the ANSI/IEEE C37.5-1979, C37.010-1979 & C37.04-1979 breaker rating methods.
- In the AEP system, all of the 138 kV breakers at Comanche station were found to exceed their interrupting capability after the addition of the generation and related facilities. Therefore, there are additional short circuit upgrade costs associated with the ERAS-2025-001; ERAS-2025-024 interconnection. Given the high fault current values AEP will need to upgrade all existing breakers and associated equipment at the station to 80 kA. Given this, the station will need to be rebuilt in the clear to accommodate this upgrade. The scope of work and cost for the breaker upgrades is included in the scope of work currently outlined in this document.

1.4 Stability Evaluation

- The stability analysis for the ERAS-2025-001 cluster will be completed in conjunction with the 2026 ITP. AEP will complete their evaluation of the results as part of that effort.

1.5 Interconnection Cost of Facilities Included in the Facilities Study:

Network Upgrades (Expanding to breaker and a half station for ERAS-2025-024)	\$34,519,475
Transmission Owner Interconnection Facilities (TOIF)	\$3,914,582
Total Cost	\$38,434,057

The estimates do not include the impact that delays in obtaining ROW, permits, or other approvals may have.

1.6 Project Lead time

Project in-service date is projected to be 36 months after the issuance of Authorization to Proceed from the Interconnection Customer.

Figure 1: Point of Interconnection (POI INFORMATION) One-Line Diagram

— Existing
— Proposed

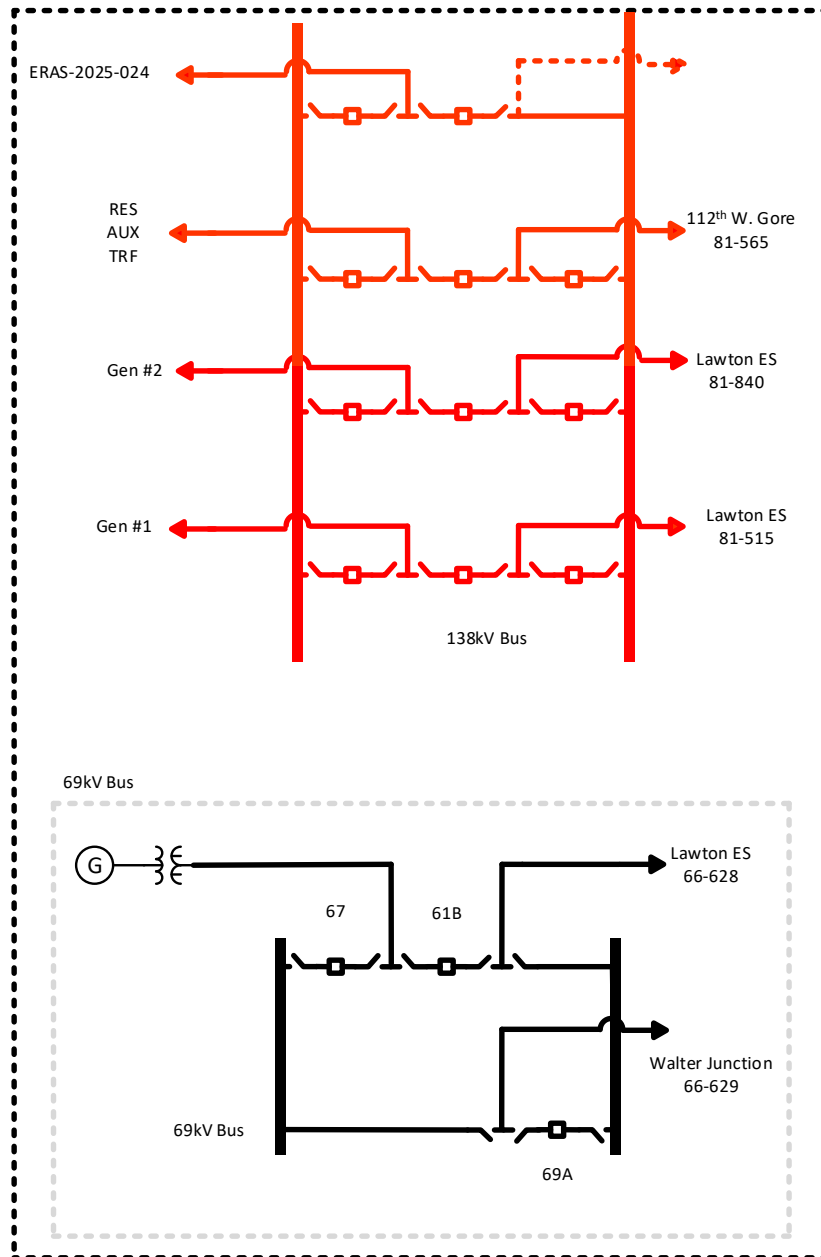

Figure 2: Point of Interconnection Maps





AEP Generation Interconnection

Facilities Study Report

for

ERAS-2025-001

**Comanche Tap to New Comanche 345 kV
Line**

Comanche County, Oklahoma

April 2026

1 Facilities Study Summary

American Electric Power (AEP) Southwest Transmission Planning performed the following study at the request of the Southwest Power Pool (SPP) for SPP Generation Interconnection request ERAS-2025-001. Per the SPP Generator Interconnection Procedures (GIP), SPP requested that AEP perform an Interconnection Facilities Study (IFS) for Network Upgrade(s) in accordance with Attachment V, Section 8.11 of the Generator Interconnection Procedures (GIP).

Comanche Tap to New Comanche 345 kV

- Build a new approx. 4-mile 345 kV line and complete the needed work to tie it into the Lawton Eastside to Terry Road 345 kV line building a new three-breaker ring bus station and the new station being built to interconnect ERAS-2025-026 expanding it to a 3 rung breaker and a half with a 330/575 MVA summer normal/emergency rating. In addition, install 2 new 345/138 kV autos to tie the new ERAS-2025-026 station to the existing Comanche 138 kV station and complete the needed expansion at each station to accommodate the connection of the autos.

1.1 Project Description

Per the ERAS-2025-001 study request, AEP proposes to build a new Comanche Tap to New Comanche 345 kV line and complete the associated station work to tie the line into the system as well as install 2 new 345/138 kV autos to tie the new ERAS-2025-026 station to the existing Comanche 138 kV station (Figure 1) in Comanche County, Oklahoma.

1.2 AEP's Scope of Work to Facilitate Interconnection

- To accommodate the request AEP will build a new Comanche Tap to New Comanche 345 kV line and complete the associated station work to tie the line into the system as well as add two 345 kV autos tying the new ERAS-2025-026 station to the existing Comanche 138 kV station.
- The design and construction of the new equipment will meet all AEP specifications for transmission lines and stations. AEP will own, operate, and maintain Comanche Tap to New Comanche 345 kV line and associated station work.
- It is understood that the Interconnection Customers are responsible for the cost of all of this work.

1.3 Short Circuit Evaluation

- It is standard practice for AEP to recommend replacing a circuit breaker when the current through the breaker for a fault exceeds 100% of its interrupting rating with recloser de-rating applied, as determined by the ANSI/IEEE C37.5-1979, C37.010-1979 & C37.04-1979 breaker rating methods.
- In the AEP system, no breakers were found to exceed their interrupting capability after the addition of this equipment. Therefore, there are no additional short circuit upgrade costs associated with the ERAS-2025-001, UIDs 172050, 172049, and 172051.

1.4 Interconnection Cost of Facilities Included in the Facilities Study:

Build a new Comanche Tap to New Comanche 345 kV line	\$29,627,840
Build a new 345 kV 3 breaker ring bus station in the LES to Terry Road 345 kV line	\$33,235,024
Install two 345/138 kV 675 MVA autos at Comanche and install the needed equipment to connect the autos and new 345 kV line	\$73,656,247
Total Cost	\$136,519,111

The estimates do not include the impact that delays in obtaining ROW, permits, or other approvals may have.

1.5 Project Lead time

Project in-service date is projected to be 48 months after the issuance of Authorization to Proceed from the Interconnection Customer.

Figure 1





AEP Generation Interconnection

Facilities Study Report

for

ERAS-2025-001

Comanche to Lawton Eastside to Duncan 138

kV Line Rebuild

Comanche County, Oklahoma

April 2026

1 Facilities Study Summary

American Electric Power (AEP) Southwest Transmission Planning performed the following study at the request of the Southwest Power Pool (SPP) for SPP Generation Interconnection request ERAS-2025-001. Per the SPP Generator Interconnection Procedures (GIP), SPP requested that AEP perform an Interconnection Facilities Study (IFS) for Network Upgrade(s) in accordance with Attachment V, Section 8.11 of the Generator Interconnection Procedures (GIP).

Comanche to Lawton Eastside to Duncan 138 kV

- Rebuild the approx. 5.2-mile line from Comanche to Lawton Eastside and upgrade terminal equipment at Comanche and Lawton Eastside to achieve the desired 330/340 MVA summer normal/emergency rating.
- Rebuild the approx. 21.6-mile line from Duncan to Comanche Tap to achieve the desired 165/250 MVA summer normal/emergency rating.

1.1 Project Description

Per the ERAS-2025-001 study request, AEP proposes to rebuild the Comanche to Lawton Eastside to Duncan 138 kV line (Figure 1) in Comanche County, Oklahoma.

1.2 AEP's Scope of Work to Facilitate Interconnection

- To accommodate the desired summer normal/emergency rating of 330/340 MVA requested for the Comanche to Lawton Eastside 138 kV line, an existing approx. 5.2-mile line will be rebuilt, and terminal equipment will be upgraded at Comanche and Lawton Eastside.
- To accommodate the desired summer normal/emergency rating of 165/250 MVA requested for the Duncan to Comanche Tap 138 kV line, an existing approx. 21.6-mile line will be rebuilt.
- The design and construction of the new equipment will meet all AEP specifications for transmission lines. AEP will own, operate, and maintain the Comanche to Lawton Eastside to Duncan 138 kV line.
- It is understood that the Interconnection Customers are responsible for the cost of all of this work.

1.3 Short Circuit Evaluation

- It is standard practice for AEP to recommend replacing a circuit breaker when the current through the breaker for a fault exceeds 100% of its interrupting rating with recloser de-rating applied, as determined by the ANSI/IEEE C37.5-1979, C37.010-1979 & C37.04-1979 breaker rating methods.
- In the AEP system, no breakers were found to exceed their interrupting capability after the addition of this equipment. Therefore, there are no additional short circuit upgrade costs associated with the DISIS-2022-001, UIDs 172053, 172060, 172055, & 172052.

1.4 Interconnection Cost of Facilities Included in the Facilities Study:

Rebuild the approx. 3.9-mile Duncan to Duncan Bois D’Arc 138 kV line	\$7,211,691
Rebuild the approx. 17.7-mile Comanche Tap to Duncan Bois D’Arc 138 kV line	\$31,306,100
Rebuild the approx. 0.9-mile Comanche Tap to Lawton Eastside 138 kV line	\$4,300,398.04
Rebuild the approx. 4.3-mile Comanche Tap to Comanche 138 kV line	\$15,826,535.47
Total Cost	\$58,644,724.51

The estimates do not include the impact that delays in obtaining ROW, permits, or other approvals may have.

1.5 Project Lead time

Project in-service date is projected to be 42 months after the issuance of Authorization to Proceed from the Interconnection Customer.

Figure 1

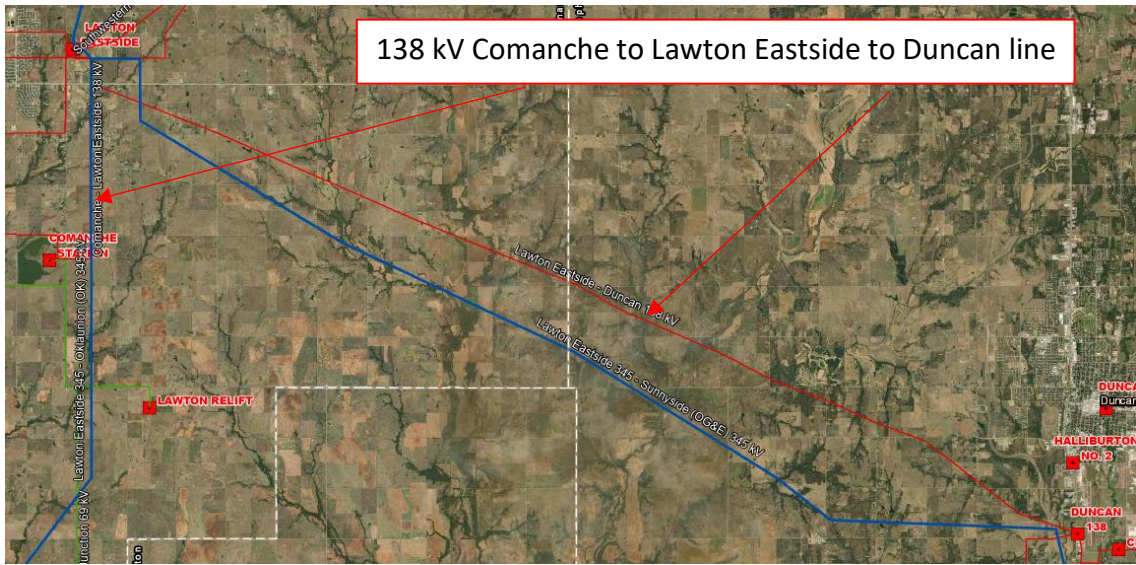



AEP Generation Interconnection

Facilities Study Report

for

ERAS-2025-001

Comanche to Lawton Eastside 138 kV Line

Rebuild

Comanche County, Oklahoma

April 2026

1 Facilities Study Summary

American Electric Power (AEP) Southwest Transmission Planning performed the following study at the request of the Southwest Power Pool (SPP) for SPP Generation Interconnection request ERAS-2025-001. Per the SPP Generator Interconnection Procedures (GIP), SPP requested that AEP perform an Interconnection Facilities Study (IFS) for Network Upgrade(s) in accordance with Attachment V, Section 8.11 of the Generator Interconnection Procedures (GIP).

Comanche to Lawton Eastside 138 kV

- Rebuild the approx. 5.2-mile line and upgrade terminal equipment at Comanche and Lawton Eastside to achieve the desired 300/320 MVA summer normal/emergency rating.

1.1 Project Description

Per the ERAS-2025-001 study request, AEP proposes to rebuild the Comanche to Lawton Eastside 138 kV line (Figure 1) in Comanche County, Oklahoma.

1.2 AEP's Scope of Work to Facilitate Interconnection

- To accommodate the desired normal/summer emergency rating of 300/320 MVA requested for the Comanche to Lawton Eastside 138 kV line, an existing approx. 5.2-mile line will be rebuilt, and terminal equipment will be upgraded at Comanche and Lawton Eastside.
- The design and construction of the new equipment will meet all AEP specifications for transmission lines. AEP will own, operate, and maintain the Comanche to Lawton Eastside 138 kV line.
- It is understood that the Interconnection Customers are responsible for the cost of all of this work.

1.3 Short Circuit Evaluation

- It is standard practice for AEP to recommend replacing a circuit breaker when the current through the breaker for a fault exceeds 100% of its interrupting rating with recloser de-rating applied, as determined by the ANSI/IEEE C37.5-1979, C37.010-1979 & C37.04-1979 breaker rating methods.

- In the AEP system, no breakers were found to exceed their interrupting capability after the addition of this equipment. Therefore, there are no additional short circuit upgrade costs associated with the ERAS-2025-001, UID 172054.

1.4 Interconnection Cost of Facilities Included in the Facilities Study:

Rebuild the approx. 5.2-mile Comanche to Lawton Eastside 138 kV line	\$20,423,908.50
Total Cost	\$20,423,908.50

The estimates do not include the impact that delays in obtaining ROW, permits, or other approvals may have.

1.5 Project Lead time

Project in-service date is projected to be 42 months after the issuance of Authorization to Proceed from the Interconnection Customer.

Figure 1

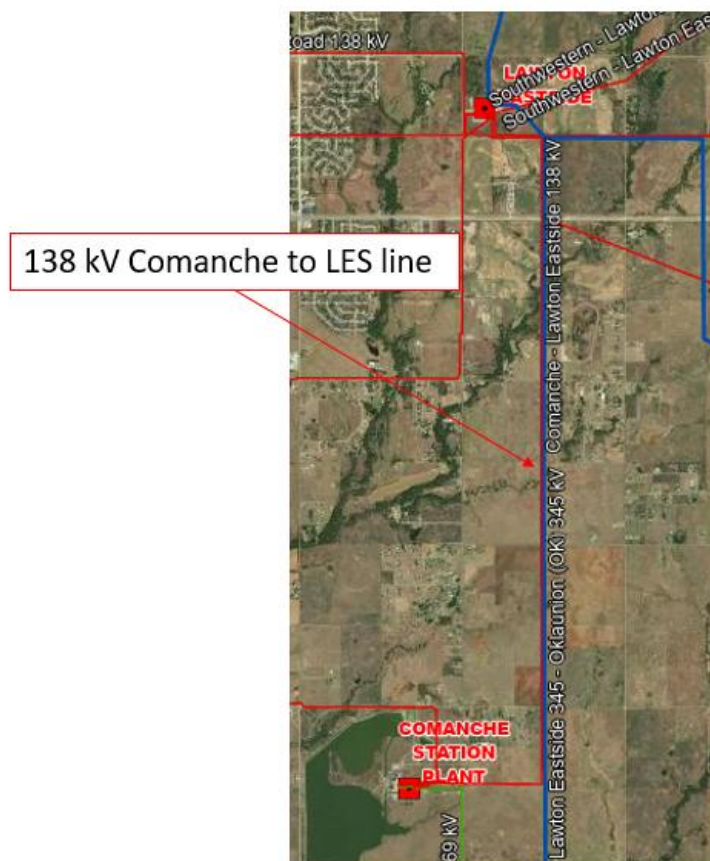



Interconnection Facilities Study

Costs associated with ERAS-2025-001 Rebuild LaCygne-G20-047 Tap 345kV Line

April 2026

Introduction

This report summarizes the scope of the Interconnection Facilities Analysis for Network Upgrade(s) to determine costs related to the addition of the SPP-GI ERAS-2025-001 Interconnection Request(s). Evergy, as a TO, is receiving an unprecedented amount of GI interconnect requests. The cost estimates and interconnect information supplied are based on current system configuration. There are many cases of multiple GI's requesting POIs at the same substation. Ongoing changes in Evergy's transmission system configuration could affect the required system upgrades and costs necessary to meet any particular GI interconnect request in the future.

Southwest Power Pool Generation Interconnection Request:

Per the SPP Generator Interconnection Procedures (GIP), SPP has requested that Evergy perform an Interconnection Facilities Study (IFS) for Network Upgrade(s) in accordance with the Scope of Interconnection Facilities Study GIP Section 8.10 and the Interconnection Facilities Study Procedures in accordance with GIP Section 8.11 for the following Interconnection Request(s):

Upgrade Type	UID	Upgrade Name	ERAS Cost Estimate	ERAS Lead Time
Current Study	172059	LACYGNE7-G20-007-TAP 345 kV Ckt 1 Rebuild	\$ 8,143,803.00	48 months

Rebuild LaCygne-G20-007-TAP (Current Study)

345kV Substation

Network Upgrades to rebuild the LaCygne – G20-007 Tap 345 kV line. This line is to be double circuited with LaCygne – Neosho for 2.25 miles back to LaCygne. Estimate also includes upgrading traps, tuners, CCVTs and bus work at the LaCygne terminal. The line and terminal are to be rated for at least 1210 MVA. UID 172059

Total Cost

The total cost estimate for this Network Upgrade is:

\$	7,056,000	Transmission Line
\$	979,485	Substation
\$	22,247	AFUDC
\$	86,070	Contingency
\$	8,143,803	Total

This estimate is accurate to +/- twenty (20) percent, based on current prices, in accordance with Attachment A of Appendix 4 of the Interconnection Facilities Study Agreement. However, recent cost fluctuations in materials are very significant and the accuracy of this estimate at the time of actual settings cannot be assured.

Time Estimate

Time estimates are based on current version of the project schedule and some processes of each category run concurrently.

Engineering Time	48	Months
Procurement Time	48	Months
Construction Time	48	Months
<hr/>		
Total Project Length	48	Months

Figure 1 – LaCygne 345/69kV Substation

